

A Rutherford
Laboratory
Monograph

Superconductivity and its applications



The background of the entire page is a microscopic image of plant cells, showing a clear hexagonal pattern of cell walls. The cells are filled with a granular, textured material, likely cytoplasm or chloroplasts. The overall color is a monochromatic blue-green.

**RUTHERFORD LABORATORY
MONOGRAPHS**

A series of short texts covering areas of science and technology in which the Rutherford Laboratory takes an active part

Series Editor: John Litt

The Rutherford Laboratory promotes university research and development work by providing facilities which are beyond the means of individual universities. As well as offering its own extensive resources, the Laboratory also provides access to important facilities at other research centres in the UK and overseas. This results in a significant level of co-operation in a wide range of projects at both national and international levels. Set up in 1957 as the first establishment of the National Institute for Research in Nuclear Science, in 1965 the Laboratory became part of the Science Research Council.



**Superconductivity
and its applications**

by Martin N Wilson

Rutherford Laboratory 1979

Superconductivity and its applications

Introduction

In 1911 Kammerlingh Onnes discovered a new and completely unexpected state of matter which he called the superconducting state. The scientific and technological consequences of this discovery have been and will undoubtedly continue to be quite remarkable. Superconductivity is a sudden and total disappearance of electrical resistance which occurs in many metals when they are cooled to very low temperature. It bears some resemblance to the curious phenomenon of superfluidity, whereby liquid helium abruptly loses all trace of viscosity when cooled to within two degrees of absolute zero. Both phenomena have been described as 'quantum effects writ large' and indeed it has only been possible to formulate a satisfactory explanation of either effect in terms of quantum theory.

Fig 1 Discrete flux lines in superconducting niobium. Each line consists of a normal core surrounded by a vortex of supercurrent. The lines tend to form a regular array, but this is distorted by the lattice dislocation in the niobium crystal visible as a jagged line in the centre of the picture. (Photograph courtesy of C P Herring.)

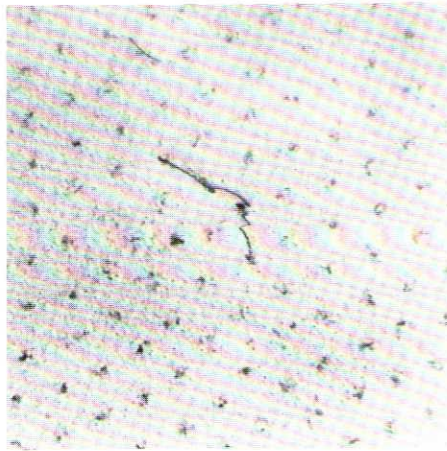

A particularly dramatic manifestation of the quantal nature of superconductivity is the Josephson effect. Devices based on this effect are now being used as microwave detectors or mixers, for the accurate measurement of voltage or magnetic field and may eventually be used as computer elements. However, most applications of superconductivity so far have been based on the simple fact that zero resistance means that large currents can be carried with no dissipation of energy. In particular, it has been possible to construct large electromagnets or electromagnetic machines which produce high fields and whose sole energy

requirement is the refrigeration power needed to keep them cold.

Superconducting Materials

Onnes' original experiment was to measure the resistance of a thread of mercury as a function of temperature. On cooling down he found a gradual decrease in resistivity as expected. At an absolute temperature of 4.15 K however the resistance suddenly disappeared. Subsequent experiments have attempted to measure the decay of super-currents induced in ring shaped specimens and have concluded that the upper limit to any resistivity in the superconductor is 10^{-25} ohm-metres, ie 10^{-17} times the resistivity of copper at room temperature. To all intents and purposes therefore we may say that the resistance is zero.

In 1933 Meissner and Ochsenfeld discovered another important property of superconductors: perfect diamagnetism, ie the superconductor will expel all magnetic flux so that the magnetic field within the superconductor is zero. This action of screening the magnetic field raises the free energy of the superconductor to the extent that, above a certain level of field, it becomes energetically more favourable for the field to move in and destroy or *quench* superconductivity. Thus we find that superconductivity can only exist below a characteristic *critical temperature* and *critical field*. Later however, it became clear that the Meissner effect of perfect diamagnetism is only shown by certain

pure metals subsequently known as *type I* superconductors and that there also exists a second class of *type II* superconductors which behave rather differently.

At very low levels of applied field, type II superconductors behave very much like type I, also exhibiting the Meissner effect. When the field exceeds a certain value however, known as the lower critical field, it becomes energetically favourable for the field to enter the superconductor. It does so in the form of discrete flux lines or *fluxoids*. Each line consists of a normal (non-superconducting) core surrounded by a circulating vortex of supercurrent. The flux enclosed by each current vortex is just one quantum unit of flux

$$\phi_0 = h/2e,$$

where h is Planck's constant and e is the electronic charge; thus ϕ_0 is 2×10^{-15} Webers. This is a very small value, for example a human hair in the earth's magnetic field will enclose $\sim 10^{-13}$ Webers. So Faraday's lines of magnetic force actually exist in a type II superconductor, albeit on a very fine scale. Fig. 1 shows a picture of the flux lines in a niobium foil; they were made visible by decorating with iron particles which were then photographed with an electron microscope. Thus, although most of the material remains superconducting – only the cores of the fluxoids are normal – the magnetic field has nevertheless been allowed to penetrate. By relieving the 'magnetic pressure' in this way, type II superconductors are able to tip the energy balance in favour of remaining in the superconducting state up to very much higher fields.

4 When currents flow in a type I superconductor, they are usually confined to a very thin layer on the surface whose thickness is called the 'London penetration depth' and is about 0.1 micron. This is true both for currents which are generated in the usual way by means of a battery and external circuit and also for those screening currents which are induced by applied magnetic fields and which sustain the Meissner effect by shielding the interior of the specimen. Although this surface current property can be useful in some applications, high frequency devices for example, it does have the disadvantage of placing a fairly severe limit on the total amount of current which can be carried through a given cross section. Fortunately type II superconductors are able to carry bulk current as well as surface currents; they do this by creating gradients in the density of fluxoids. The flux line array shown in Fig. 1 has a fairly uniform and regular appearance. This is because there is a mutually repulsive force between the fluxoids so that, in the absence of other forces, they tend to arrange themselves into a regular array. A uniformly spaced array implies a uniform field (each carries one flux unit) and therefore zero current. The uniformity of this array may be disturbed however by the imposition of additional forces such as will arise from imperfections in the crystal lattice or *pinning centres*, eg impurity precipitates, dislocation cells etc. A non-uniform array of flux lines implies a field gradient and therefore a current. Thus we find that pure, well annealed samples of type II superconductor are unable to carry bulk

currents whereas impure cold worked specimens, with plenty of lattice imperfections or pinning centres, are able to carry large bulk currents as well as surface currents.

Practical Superconductors

Following Onnes work with mercury, it has since been found that 24 metallic elements become superconducting below critical temperatures which range from 9.2 K down to 0.01 K. Most of the elements are type I, often known as soft superconductors because they include many metals like tin, lead, indium, etc. In addition to the pure metals there are now more than a thousand superconducting alloys or compounds, mainly type II, with *critical temperatures* T_c up to 23 K and *critical fields* B_c up to 60 Tesla. The continuing search for new materials with higher critical fields and temperatures has become a lively area of materials science. Once a new material with given B_c and T_c has been identified, it is usually necessary to modify the microstructure in some way to develop a good current carrying capacity, ie to produce plenty of pinning centres. This may be achieved for example by cold working, by the addition of impurities or by a precipitation heat treatment. Even when a material has been developed which is satisfactory in all these respects, further developments in the area of fabrication technology are usually needed before the conductor can be produced in a form which is suitable for the construction of superconducting magnets and other devices.

Fig. 2 shows the critical surface of the alloy niobium titanium – presently the most common technical superconductor. At all levels of field, current and temperature below this surface niobium titanium is able to remain superconducting, but if any of these three parameters is increased above the surface, the material will switch to the normally conducting state. A very common operating temperature for superconducting devices is 4.2 K, the boiling point of liquid helium; at this temperature the critical field is ~ 10.5 Tesla, but one would normally not choose to operate above ~ 9 Tesla because the current density becomes too small. Nevertheless these performance figures represent a very substantial improvement over conventional iron cored electromagnets and electrical machinery which operate at current densities below ~ 20 amps/mm² and produce fields of ~ 2 Tesla. Niobium titanium is a ductile alloy which may readily be fabricated into wire, indeed the wire drawing process (cold work) is essential to the development of a high critical current density. It was discovered, along with many other 'high field' superconductors, in the early 1960s.

Early attempts to wind magnets from superconducting wire were extremely disappointing. It was found that the magnets reverted to the normal state or quenched at currents far below those expected from the critical surface of Fig. 2. Eventually it became clear that this degradation in performance was being caused by the local release of small pulses of energy within the magnet winding.

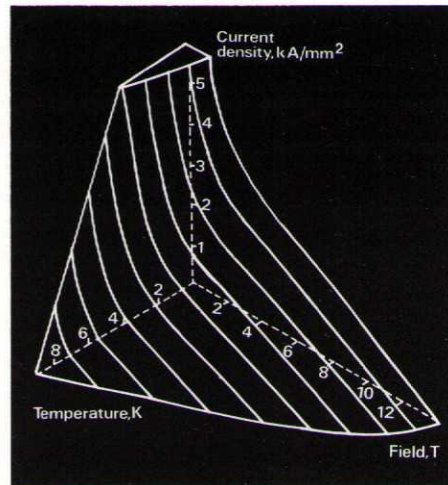

Fig 2 The critical surface for niobium titanium alloy. Superconductivity prevails below the surface, and normal resistivity above the surface.

6 Because specific heats are very small at low temperatures, even quite modest pulses of energy are sufficient to raise the temperature above the critical surface and cause the superconductor to switch into its normal state. When this happens there will be intense ohmic heat generation in the superconducting wire which will raise the temperature of the surrounding region of the winding. The normal region thus grows in a catastrophic and irreversible fashion until all the magnet energy has been dissipated as heat. The magnet is said to have *quenched*, probably boiling off a considerable quantity of liquid helium in the process. When this happens one can only switch off the current supply, wait until the magnet cools down, and then try again. Clearly this is a most unsatisfactory state of affairs and the widespread use of superconducting magnets had to await the development of suitable 'stabilization' techniques which prevent premature quenching and allow magnets to work reliably up to their design current.

One very inconvenient property of type II superconductors, which is at first sight surprising, is that the normal state resistivity is very high; in addition, the thermal conductivity is very low. If the superconducting wire is coated with a good normal conductor, such as copper, both these properties will be greatly improved. The ohmic heat generation in small normal zones will be reduced and this heat may be conducted away more effectively. Not surprisingly therefore, magnets wound from copper coated wire were found to perform much better. Furthermore, the risk of damage to the

magnet by overheating or excess voltage at a quench was greatly reduced.

The technique of *cryostabilization*, invented by Laverick and Stekly in 1965, also makes use of a copper coated superconductor. In addition however the magnet winding is provided with cooling channels so that the conductor is everywhere in contact with liquid helium. Fig. 3 illustrates what happens when a local energy pulse impinges on the superconductor: the temperature rises, the superconductor becomes normal, current switches to the copper generating heat, liquid helium coolant removes the heat, temperatures fall, the superconductor recovers and resumes its current carrying duty. The performance of this kind of conductor will evidently be determined by the resistance of the copper and heat transfer to liquid helium as well as the properties of the superconductor. Fortunately the resistivity of pure copper decreases as it is cooled to 4.2 K; typical values are $\sim 1/200$ of the room temperature value. Nevertheless it is still necessary to use substantial quantities of copper, simply because the superconductor is able to operate at such high current density; a typical cryostabilized conductor will contain between 10 and 50 times as much copper as superconductor. Fig. 4 shows a short length of cryostabilized conductor with its cooling channels.

The technique of cryostabilization made it possible, for the first time, to design large superconducting magnets in the certain knowledge that they would work at their

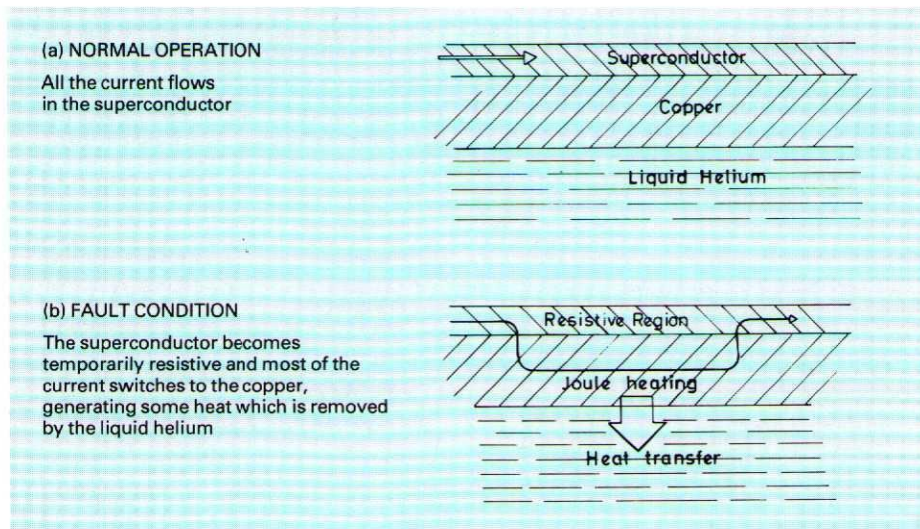

Fig 3 The principles of cryostabilization.

Fig 4 A typical cryostabilized conductor.

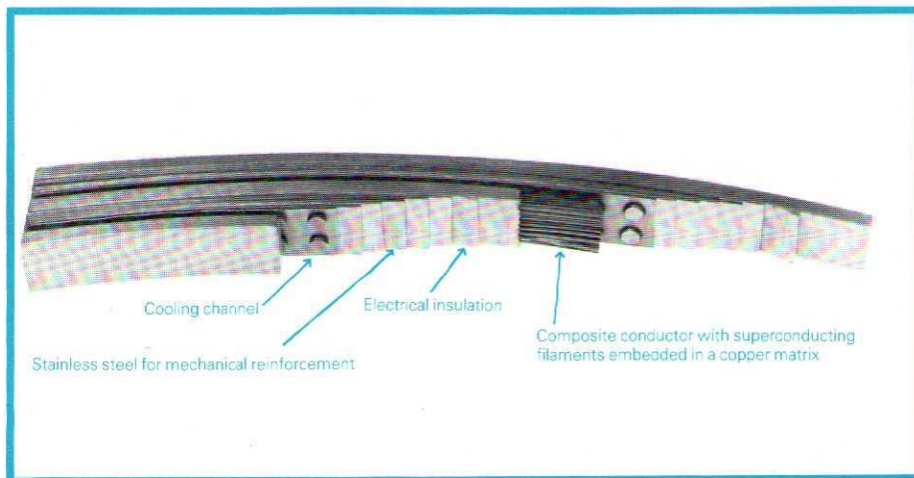



Fig 5 Superconducting magnet coils for the Big European Bubble Chamber. (Photograph courtesy of the CERN Laboratory, Switzerland.)



design current. Many large magnet systems have been built in this way: Fig. 5 shows the magnet coils for the Big European Bubble Chamber at the CERN Laboratory in Geneva.

Although cryostabilization has proved itself to be very reliable in practice, it does suffer from one major disadvantage, the large dilution of current density by the copper. Low overall current densities mean that the windings needed to generate a useful level of magnetic field must be inconveniently large. To take advantage of the much higher intrinsic current densities offered by superconducting materials, it is necessary to use a different approach. One obvious way is to try to eliminate the pulses of energy which are the basic cause of the trouble.

It turns out that a major source of energy release in magnet windings and other superconducting devices is a phenomenon known as *flux jumping*. This is a kind of electromagnetic/thermal instability which is liable to occur in all type II superconductors when the magnetic field is increased. Fig. 6 shows how the superconductor tends to set up bulk shielding currents which reduce the field in its centre. The strength of these screening currents is determined by the critical surface for the material. A small temperature increase will always reduce the screening currents (see Fig. 2) thus causing an increase in the general level of field within the superconductor, as shown by the dotted line in Fig. 6. Although superconductors are usually loss

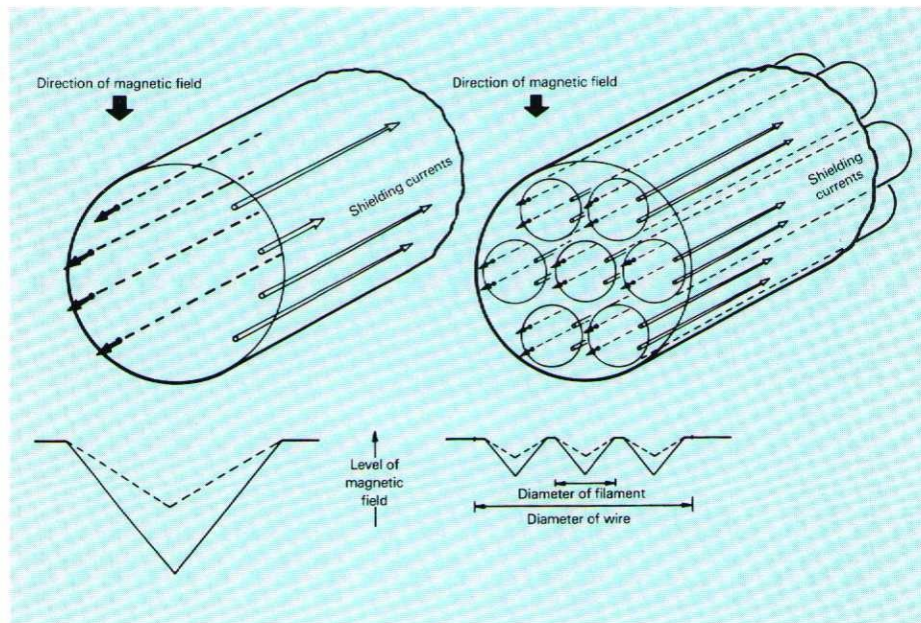
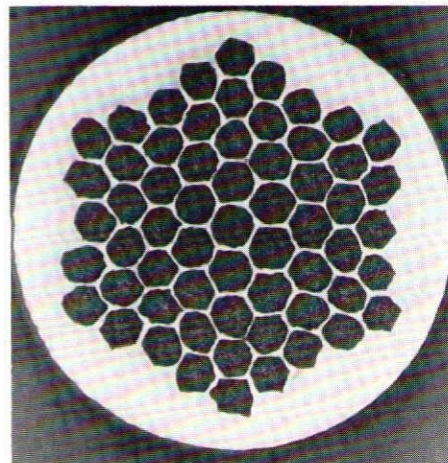

Fig 6 Screening currents induced in a superconducting wire by a magnetic field. These currents are prone to an instability known as 'flux jumping'. The extent of the currents, the amplitude of the screened field and the likelihood of flux jumping may all be reduced by fine subdivision, as shown in the right-hand diagram.

Fig 7 Cross-sectional view of a 61-filament superconducting composite wire. The overall wire diameter is about 0.5 mm and the diameter of each filament is about 40 micron. The filament material is niobium titanium and the matrix material is copper. (Photograph courtesy of Imperial Metal Industries Limited.)



free materials, the motion of flux within them is actually a lossy process and this redistribution of the internal field will therefore release heat. The consequent rise in temperature then causes a further reduction in screening current, more flux motion, more heat and therefore further increase in temperature. It is not difficult to appreciate how this 'positive feedback' process can, under the right conditions, turn into an avalanche so that a tiny perturbation in temperature can release substantial quantities of energy and thus cause a magnet to quench. The most effective cure for this problem so far devised has been to divide the superconductor into very fine filaments (50 micron diameter or less). This reduces the extent of flux motion associated with a given change in screening current density, as shown in Fig. 6. Furthermore, if the filaments are embedded in a metal of high thermal conductivity, eg copper, the temperature rise resulting from a given energy release will be reduced (remember that superconductors have very poor thermal conductivity). Fig. 7 shows the cross section of a typical filamentary composite wire. In a practical conductor it is also necessary to twist the wire like a rope, to reduce magnetic coupling between filaments.

Although fine subdivision has proved a very effective cure for flux jumping, it has not completely solved the problem of degraded performance in magnets. Many coils still quench at currents somewhat below those expected from the critical surface of the wire. In addition they often show *training*, ie the second quench

occurs at a higher current than the first and the coil performance shows progressive improvement with successive quenching until it becomes constant at some higher current level. In this way the full critical current may eventually be attained in small or medium sized magnets, but in larger coils the training usually stops at some lower value. The effect is thought to be caused by the mechanical release of energy inside the coil, ie slippage, microcracking, etc under the influence of the electromagnetic forces. It has been investigated at several laboratories and some improvements in performance have been obtained. However for reliable performance in large magnets, cryostabilization is still to be preferred.

An additional advantage of fine subdivision is that it allows the superconductor to be used in changing fields, ie ac. Conductors employing bulk type II superconductor cannot be used in this situation because the losses caused by flux motion create an intolerable refrigeration load. With fine filaments, the load can be reduced to a reasonable level, although unfortunately not low enough for most 50 Hz applications. Fig. 8 shows the cross section of a very finely divided composite developed for a possible superconducting synchrotron magnet pulsing at $\sim \frac{1}{4}$ Hz.* Because it is ductile and relatively easy to

*For their work on the development of filamentary superconductors, the groups at Rutherford Laboratory and Imperial Metal Industries Limited were awarded the British Cryogenics Society prize in 1970.

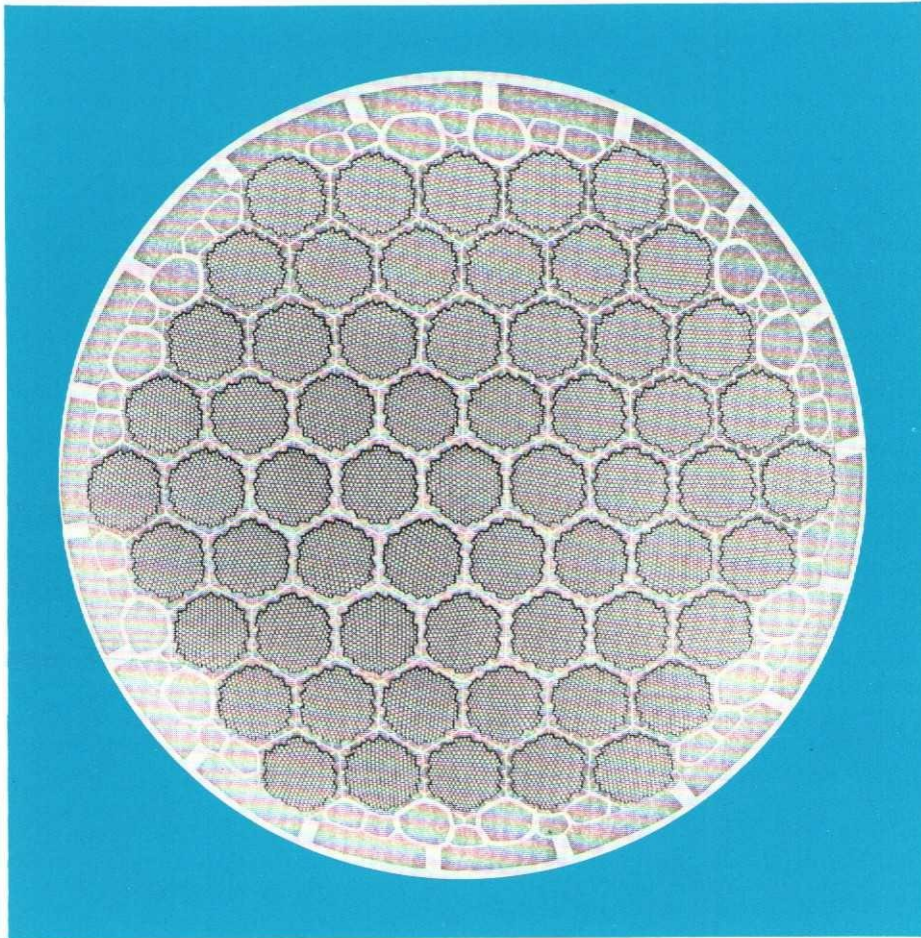

Fig 8 Cross-sectional view of a 14,700-filament superconducting composite wire used for pulsed field applications. The wire diameter is about 1.0 mm and the filament diameter is about 5 micron. The superconductor material is niobium titanium and the matrix is pure copper with a web of cupro-nickel resistive barriers. (Photograph courtesy of Imperial Metal Industries Limited.)

fabricate, niobium titanium has become the standard 'work horse' of the superconducting magnet business. It is usually produced by electron beam melting of the alloy to form a billet which is then copper clad, extruded and drawn to rod. The rod is then cut into many short lengths which are stacked into copper cannisters, extruded and drawn to fine wire. A third stage of extrusion with 'double stacking' is often used to make extra fine filaments. As shown in Fig. 9 however, there are several other materials with superconducting properties which are superior to niobium titanium. Unfortunately they are all brittle intermetallic compounds which are difficult to fabricate. The best fabrication techniques so far have been developed for the compound niobium tin. One approach is a chemical vapour deposition technique whereby the gaseous chlorides of niobium and tin are reduced at high temperature, causing a layer of niobium tin to be deposited on a ribbon of stainless steel. Although the conductor produced in this way is finely divided in one direction, it is still prone to flux jumping because the tape is quite wide. A filamentary composite would be preferable and these have recently been produced by a process known as the bronze route. Using techniques very similar to those developed for niobium titanium, a filamentary composite of pure niobium in copper/tin bronze is first produced. This composite is then given a reaction heat treatment which causes the tin to migrate through the bronze and react with the niobium, thereby producing a layer of niobium tin on each filament.

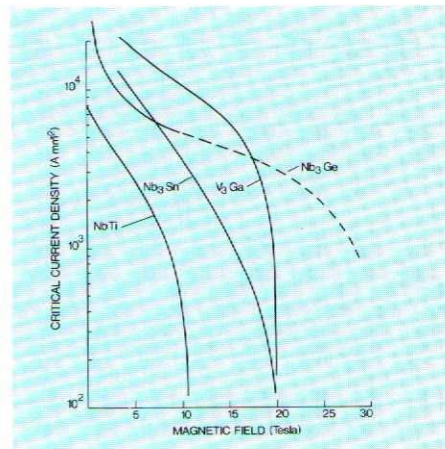
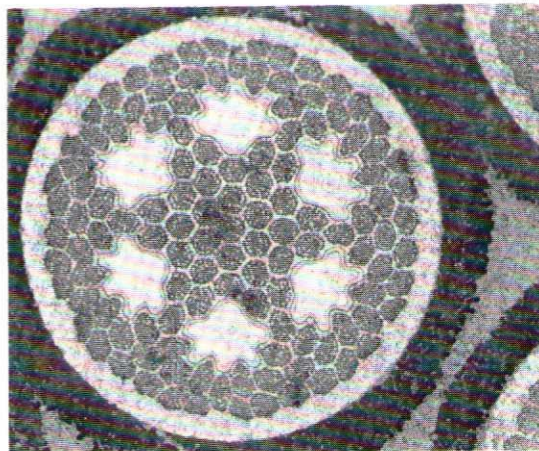

Fig 9 The critical current densities of some high field superconducting materials.

Fig 10 Cross-sectional view of a filamentary niobium tin magnet showing the 0.5 mm diameter wires insulated by glass-fibre and encapsulated in epoxy resin. Each wire contains 4,477 filaments of niobium tin of about 3 micron diameter in a bronze matrix with 6 large filaments of pure copper. (Photograph courtesy of AERE Harwell.)



Magnetic Applications of Superconductivity

High Energy Physics

The use of large cryostabilized superconducting magnets in bubble chambers and spark chambers has already been mentioned and several such magnets are now in regular operation at high energy physics laboratories throughout the world. They are the largest superconducting magnets constructed so far and the largest of them all is for the Big European Bubble Chamber at the CERN Laboratory (Fig. 5). This produces a field of 3.5 Tesla in a bore diameter of 4.7 m with a stored magnetic energy of 730 megajoules.

An even larger scale application, although it actually involves smaller magnets, is the synchrotron accelerator itself. At present these machines use conventional magnets producing fields of ~ 1.8 Tesla. The magnet ring of a large accelerator such as the 500 GeV synchrotron at the Fermi National Accelerator Laboratory in the USA consists of over 1000 magnets arranged in a 2 km diameter circle. If these were superconducting magnets producing a higher field, the energy of the accelerator could be raised accordingly. The first large-scale superconducting project of this nature is the 400 GeV ISABELLE accelerator now under construction at the Brookhaven National Laboratory in the USA. This machine will be a combined accelerator and storage ring; two magnet rings will run quite close to each other for most of their

circumference and overlap in two straight intersection regions. Protons are accelerated in opposite directions in each ring and collide *head-on* in the intersection region. The centre-of-mass energy released in this way is much greater than in the more usual approach of firing a single beam of protons at a stationary target. Fig. 11 shows a short test section of the magnet ring consisting of two superconducting dipole magnets, which produce a uniform field of 4 Tesla to bend the proton beam, and one quadrupole magnet, which produces a non-uniform field to focus it.

Controlled Thermonuclear Fusion

Magnetic confinement of a hot deuterium tritium plasma is presently thought to be the most promising route towards the commercial production of power from controlled thermonuclear fusion. It is generally agreed that any magnetic confinement scheme will have to use superconducting magnets if it is to be economic. The scale of such a reactor would be immense in comparison with any superconducting system built so far. Fig. 12 shows an artist's impression of a conceptual design by the Culham Laboratory for a 2500 megawatt Tokamak reactor system. The hot plasma is to be confined in a toroidal or doughnut shape by means of a toroidal ring of large D-shaped superconducting coils. Each coil is over 20 metres tall and the complete ring produces a peak field of 8 Tesla. Another set of poloidal field coils is also needed to produce a changing magnetic field in the vertical direction. This serves to induce a circulating current in the plasma

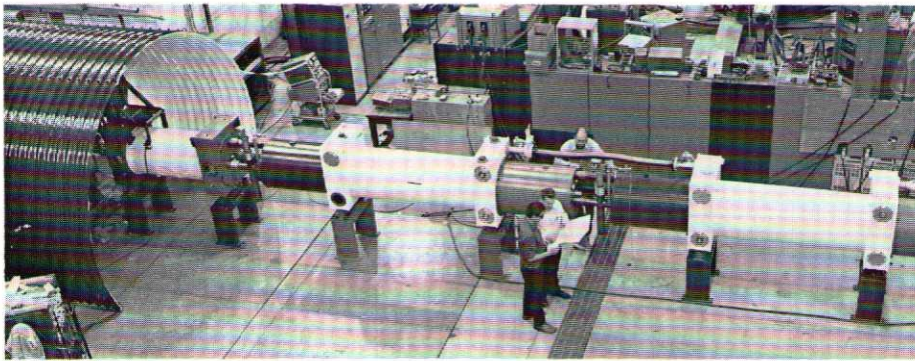
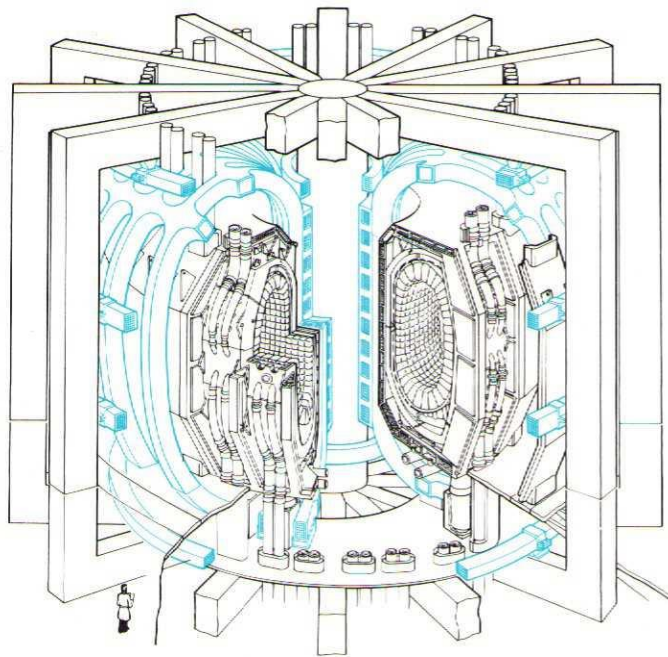

Fig 11 Testing a prototype section of the superconducting accelerator ISABELLE.
(Photograph courtesy of the Brookhaven National Laboratory, USA.)

Fig 12 Conceptual design for a 2,500 megawatt power generating Tokamak fusion reactor.
(Design courtesy of the Culham Laboratory.)



– just like a single turn transformer – which heats the plasma and stabilizes it. The heat and fast neutrons generated within the plasma are absorbed by a shield which surrounds the plasma vessel. Heat is then removed from the shield and used to generate electric power in the usual way.

Magnetohydrodynamic Power Generation

This is a technique for the direct conversion of thermal energy to electrical energy. On a rather shorter time-scale than fusion, it seems likely that magnetohydrodynamic power generation could enable us to make more efficient use of the existing energy sources. It would do so by increasing the top temperature and hence the efficiency of the working cycle of an electricity generating plant. Instead of a steam turbine and conventional generator, a hot ionized gas would be employed as the working substance. It would be made to flow at near sonic velocities through a duct within a magnetic field. The resulting voltage and current induced in the gas would be picked off by a series of electrodes lining the duct and used as a source of dc electric power. A conventional steam generating plant would then be used to extract some fraction of the energy remaining in the gas.

Very large volumes of magnetic field would be needed to enclose the duct of a commercial magnetohydrodynamic power plant, and once again superconducting

magnets are the only possibility; a conventional magnet would probably consume as much power as the plant produced. Fig. 13 shows an experimental superconducting magnet for magnetohydrodynamic power generation recently constructed at the Argonne National Laboratory in the USA for use at the High Temperature Institute in Moscow. It produces a transverse field of 5 Tesla in a duct 0.4 m diameter and 2.5 m long. The magnet for a commercial power plant would be about six times as big in all dimensions.

Motors and Generators

Although the ac losses due to flux motion forbid the use of superconducting magnets at power frequencies, they can nevertheless be used to produce dc fields in electric motors and generators. The advantages to be obtained from so doing include improved efficiency and a large reduction in size and weight. Fig. 14 shows a 1 megawatt motor generator system constructed at International Research and Development Co. Ltd., Newcastle, as a prototype ship propulsion unit. Both motor and generator work on the homopolar principle whereby a disc rotates in an axial magnetic field; current enters the disc via brushes on its axis and leaves from the periphery. The axial field is produced by a large superconducting solenoid but the disc, brushes and external current circuit use conventional conductors.

It also seems probable that very large ac generators will eventually use

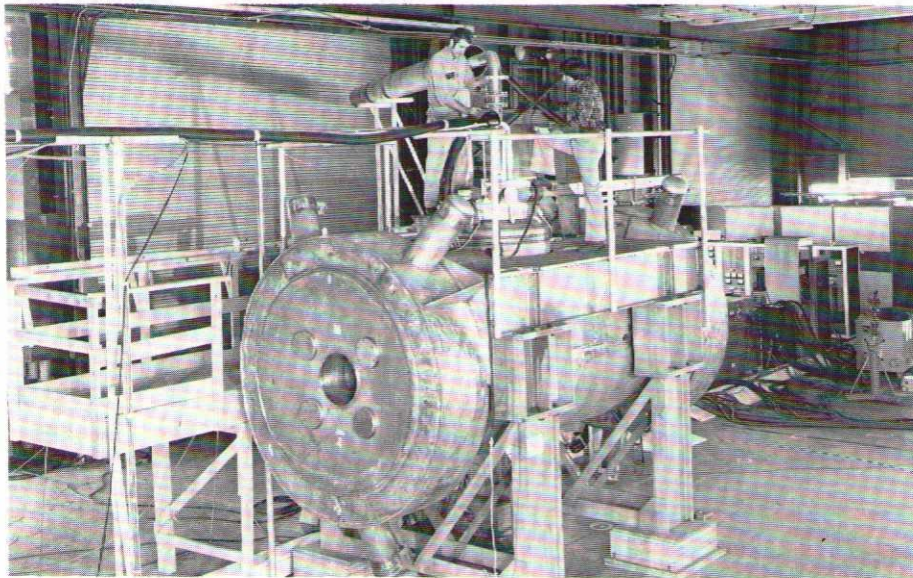

Fig 13 A large superconducting dipole magnet for experiments in magnetohydrodynamic power generation. (Photograph courtesy of the Argonne National Laboratory, USA.)

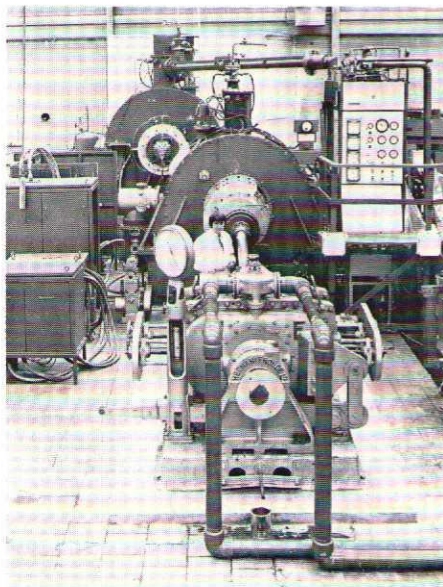
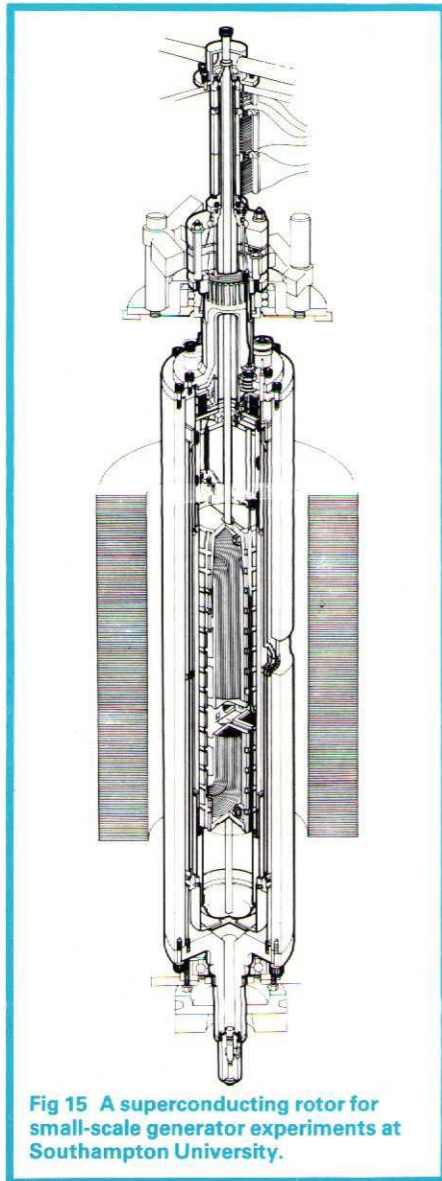

Fig 14 A prototype superconducting marine propulsion system showing a 1 megawatt generator, a 1 megawatt motor and (in the foreground) the water brake. (Photograph courtesy of the International Research and Development Company Limited.)



superconducting field windings. Present design studies indicate that these could become economically competitive with conventional generators at power ratings above 1000 megawatt. The usual design of generator involves a rotating field winding, which creates some technical difficulties for the superconducting magnet system. Fig. 15 shows a small-scale rotating magnet system under construction at the Rutherford Laboratory for use in an experimental generator programme at Southampton University.

Research Magnets

The use of small superconducting magnets as a laboratory research tool is now well established and such magnets may now be purchased on a regular commercial basis to provide fields of up to 14 Tesla in bores of a few centimetre diameter. A particularly interesting application of such magnets is in nuclear magnetic resonance work where fields are needed which are highly uniform in space and time (parts in 10^9). Uniformity in time may be obtained very easily in a superconducting coil by operating in the 'persistent mode'. This simply means that, with the magnet at full current, a superconducting link is put across its terminals so that the current continues to circulate in a closed loop. For the purposes of charging or discharging the coil, the superconducting link is driven into the normal state, usually by means of a small heater. The technical problem of producing good superconducting joints is a difficult one and usually some slight

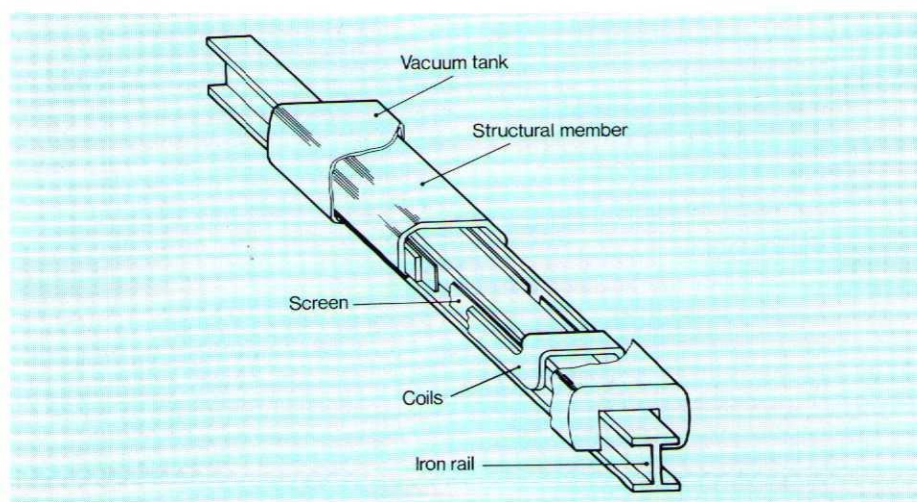

Fig 16 A possible magnetic levitation system for high speed transport.

particles may be used to scavenge the bacteria and other contaminants.

resistance remains in the circuit giving decay time constants of many years.

Magnetic Separation

This is an activity where superconductivity may eventually be used on a routine industrial basis. Using a steel wool filter in a magnetic field, it has proved possible to separate iron oxide particles from clay, steel particles from rolling mill effluent, sulphur from coal and even red cells from blood. The scope of this technique may be considerably extended by *seeding*, ie by previously adding ferromagnetic *scavenger* particles which attach themselves to whatever needs to be filtered out. A good example of this is in water treatment where colloidal iron oxide

Magnetic Levitation

The lightweight compact nature of superconducting magnets affords some advantages in transport applications and several magnetic levitation schemes are presently under investigation for use in high speed transport. One such scheme, the 'mixed permeability' system, was recently devised at the Culham Laboratory and has been investigated at the Rutherford Laboratory. It takes advantage of the inherently diamagnetic nature of superconductors to produce stable levitation of an array of superconductors with respect to a piece of iron. Fig. 16 shows a possible design for a cryogenic levitation unit hovering above a (room temperature) iron rail.

20 **Some Other Applications**

Power Transmission

The use of superconducting cables to transmit electric power without resistive loss is perhaps the most obvious application for superconductivity. Economic considerations are always very prominent in all aspects of power generation and distribution however and present analysis suggests that superconducting power transmission will not be competitive until it is necessary to transmit about 5000 megawatt underground through a single cable. For the UK this implies a three or four fold increase in the size of the generating system.

In spite of these relatively unattractive economics, superconducting cables are being investigated in several laboratories throughout the world. A basic choice has first to be made between ac and dc cables. The dc cable can use type II superconductors to carry bulk currents, thus enabling a high current capacity to be fitted into a small cross section. It is necessary however to provide expensive rectifier/inverter plant at each end of the cable. The ac cable must use type I superconductors or type II at low fields (~ 0.01 Tesla) so that all currents are carried by the London surface layer in a relatively loss free fashion. This eliminates the need for rectification but makes the cable fairly bulky.

Microwave Cavities

Provided one remains in the surface current regime, ie keeps the magnetic

field small, superconductors can be used up to very high frequencies with very small loss. It has therefore been possible to produce microwave cavities with quality or Q factors of $\sim 10^{10}$ to 10^{11} , which are extremely high in comparison with conventional copper cavities where Q is $\sim 10^4$ to 10^5 . The power requirements for a given structure may thus be greatly reduced; as a general rule this means that it can be powered continuously rather than in short pulses as is usually the case with conventional high-power cavities. Superconducting cavities are therefore starting to be used for accelerators, particle separators and microwave oscillators of high frequency stability.

Bolometers

The sharp transition between superconducting and normal states in pure metals can provide a sensitive indication of temperature. Specific heats are very small at low temperatures. These two properties are utilized to advantage in the superconducting bolometer which has been developed into a working detector for the far infra-red region with a sensitivity of $\sim 3 \times 10^{-15}$ watt/Hz $^{1/2}$. The detector consists basically of a thin film of superconductor connected via a thermal impedance to the helium bath. A sensing current is passed through the film which is set up so that it is just poised on the edge of the superconducting normal transition.

Applications of the Josephson Effect

In 1962 Josephson predicted theoretically that, in the situation where two

superconducting materials are separated by a very thin insulating barrier, some very unusual effects might be expected. He found that it should be possible for the superconducting electrons to *tunnel* through the barrier, ie that a superconducting current should flow across the junction. The amplitude of this current is determined by the difference in phase between the quantum mechanical wave functions on each side of the barrier – which in turn depends on the magnetic field. If a steady voltage is maintained across the junction, the phase difference will change with time and cause the supercurrent to oscillate at high frequency. If on the other hand an ac current is applied to the junction, eg by irradiation with microwaves, a dc voltage will appear across the junction. The relationship between this voltage and the frequency of the radiation is remarkably simple:

$$nh\nu=2eV$$

where n is an integer, h is Planck's constant, ν is the frequency, e is the electronic charge and V the voltage.

Josephson's predictions were quickly confirmed by experiment and the effect is now starting to be exploited in a wide range of devices. In practice the barrier or 'weak link' between the two superconductors can be produced in a variety of ways. Thin film technology may be used to deposit two superconducting films with a thin insulating film between them. Another approach uses the point contact obtained by gently pressing a fine point of, say, niobium superconductor onto another piece of niobium. Yet

another technique is to deposit a solder blob onto an oxidized wire – a superconducting dry joint! Three major applications of the Josephson effect are described in the following paragraphs; in addition it has been used in microwave generators, detectors, mixers and parametric amplifiers and also as a detector for the far infra-red.

Computer Switching

Fig. 17 shows the current/voltage characteristic of a (tin, tin oxide, tin) Josephson junction at 1.8 K. It may be seen that there are two quite separate branches, one superconducting and one resistive. The superconducting branch, OA with zero voltage, is attributed to Josephson tunnelling by the condensed superconducting electrons or *Cooper pairs*. The resistive branch OB may be attributed to tunnelling by normal electrons or *quasi particles*. A small magnetic field applied to the junction will change the maximum allowed value of the Josephson current and will in fact reduce it to zero when the junction encompasses one quantum of magnetic flux. An additional superconducting control wire may therefore be used to switch the junction by imposing a magnetic field on it so that the operating point jumps from A to B in Fig. 17. Depending on the circuit parameters, the junction will either *latch* in the resistive zone or recover the superconducting state when the control current is removed. Extremely fast switching times $\sim 60 \times 10^{-12}$ sec have been achieved, together with a very low power dissipation of $\sim 3 \times 10^{-6}$ watt. If

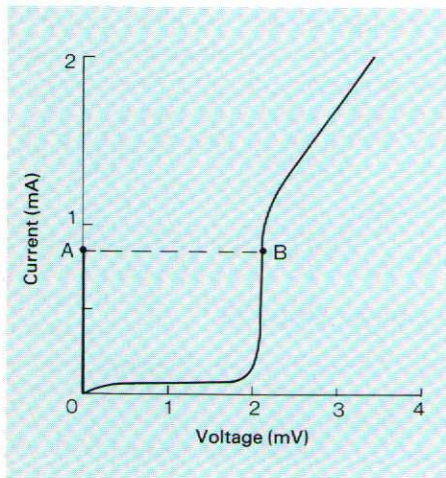

Fig 17 Typical characteristics of a Josephson junction of tin/tin oxide/tin at 1.8 K. Branch OA is attributed to supercurrent tunnelling and OB is tunnelling by normal electrons.

reliable and economical fabrication techniques can be developed, the Josephson junction must surely prove a strong contender for the large computers of tomorrow.

Squids

This delightful acronym encompasses a whole family of Superconducting Quantum Undulating Interference Devices. They are all based on the fact that magnetic flux within a superconducting loop is quantized in units of ϕ_0 . When an external magnetic field is applied, current will be induced in the loop to maintain the flux linked. If the loop contains a weak link, eg a point contact, the amplitude of this current will be limited to some maximum value. If the applied field is increased beyond this level there will be a sudden jump in current as the loop admits one more unit of flux. This process can continue over many jumps making it possible to count individual flux quanta. In practice the jumps are usually counted by arranging for the SQUID to be the coupled secondary of an rf oscillating circuit.

The SQUID has now been developed into a fairly rugged, reliable and commercial measuring instrument. Remarkably high sensitivities are possible, for example with a loop area of 1 cm² and a resolution of one part in a thousand between successive flux quanta (2×10^{-15} Weber), it is possible to detect a field change of 2×10^{-14} Tesla. This has set a new standard of magnetic field measurement and made it possible, for example, to

make diagnostic measurements of the magnetic fields generated by the brain or the heart.

By coupling the SQUID to a current carrying loop, one may measure currents to a resolution of $\sim 10^{-12}$ amp at 1 Hz. Alternatively the same arrangement may be used as a null detector in a potentiometer circuit to measure voltage to $\sim 10^{-13}$ volt or resistance to $\sim 10^{-11}$ ohm.

A Voltage Standard

The basic relationship $2eV = nh\nu$ holds quite independently of junction materials, geometry, temperature, etc and enables one to relate voltage to the fundamental units e and h via a measurement of frequency. Modern counting techniques enable frequency to be determined very accurately, making the Josephson junction an ideal standard of voltage. The usual technique employed in practice is to irradiate the junction with microwaves and trace out a current/voltage curve. This curve is found to have a regular series of steps of voltage width $h\nu/2e$. The best of these measurements has yielded an accuracy better than one part in a million, which is so much better than any other kind of measurement that the *Josephson volt* has now become the internationally accepted standard.

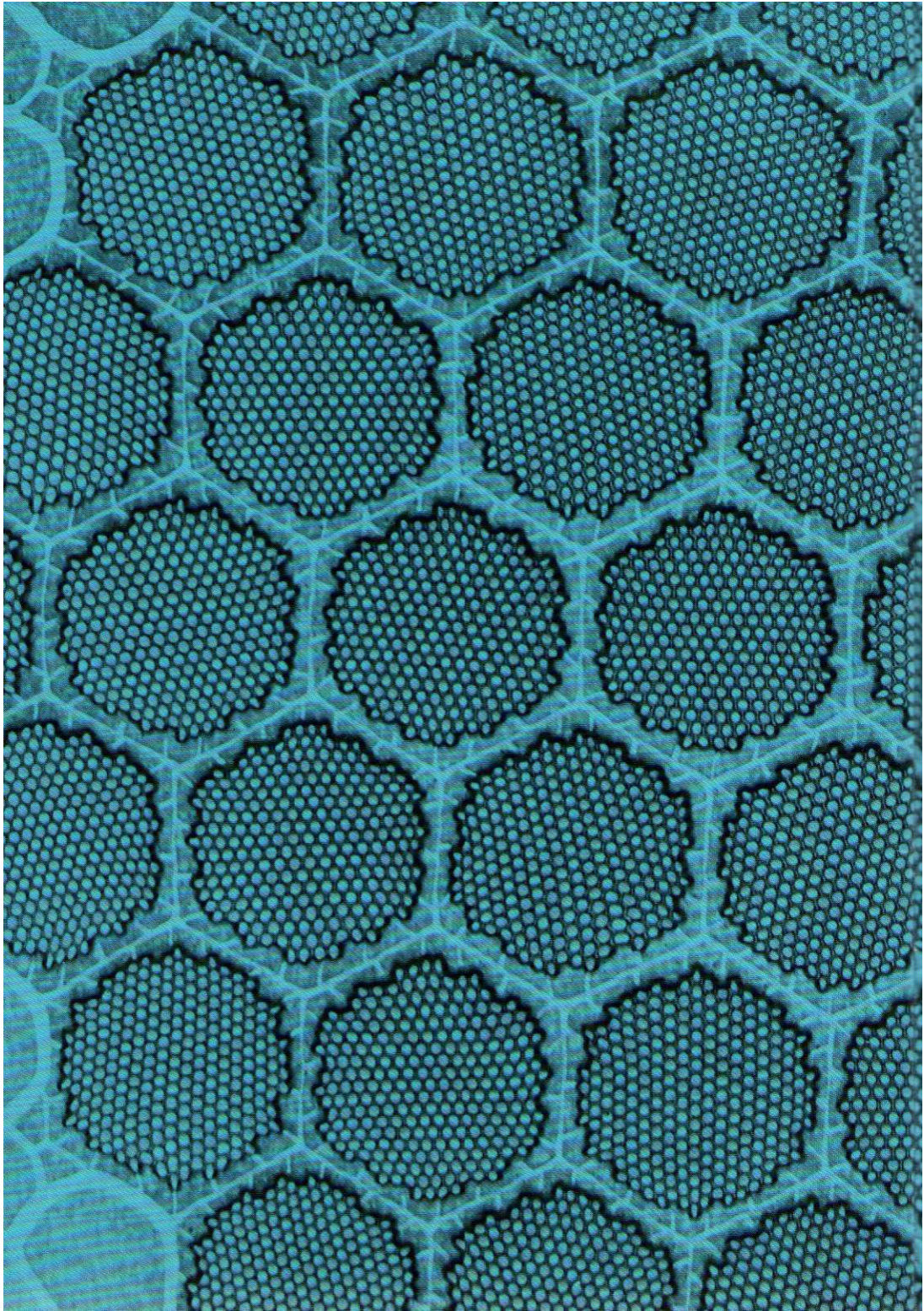

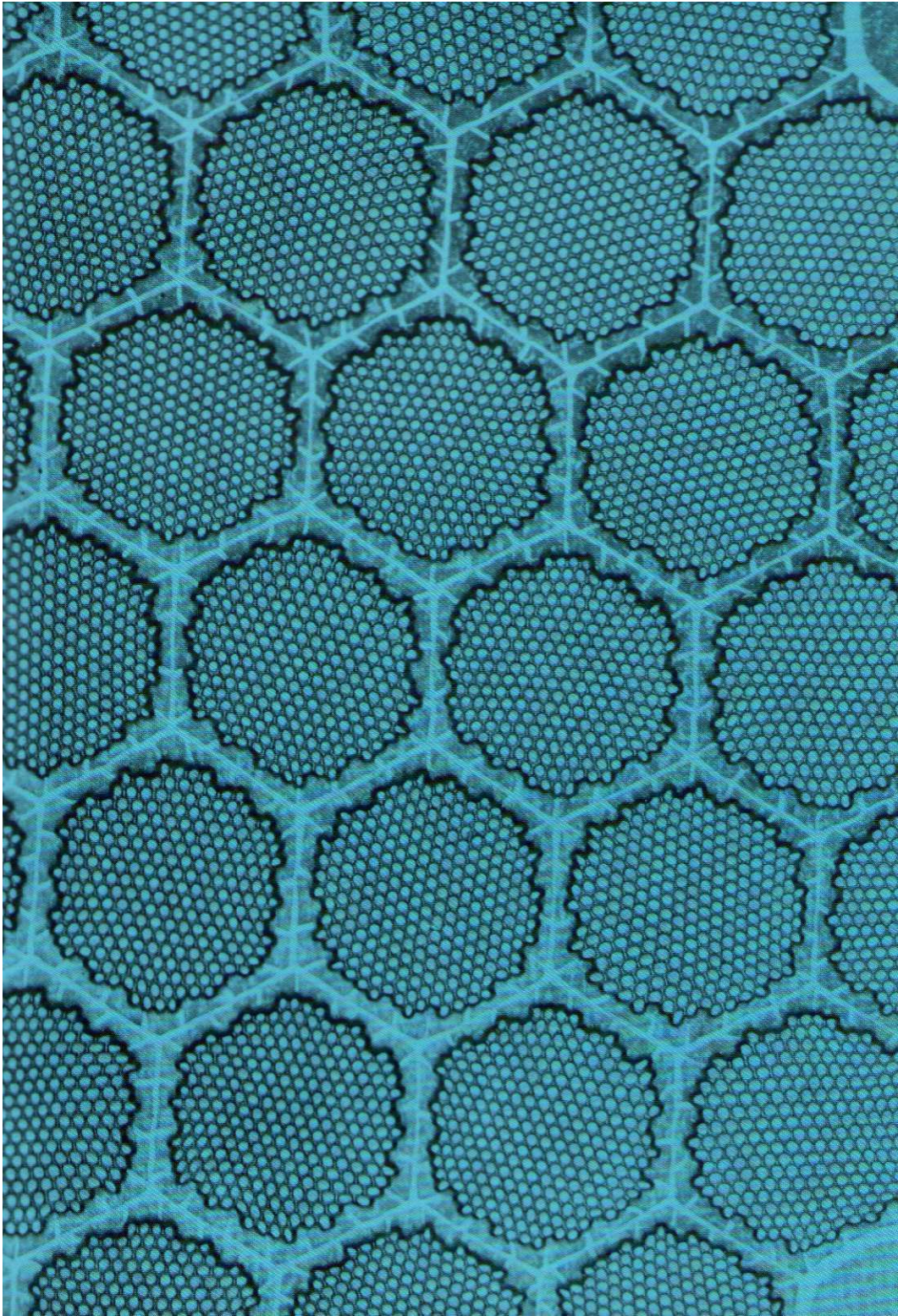

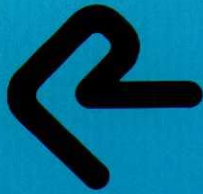

RUTHERFORD

Science Research Council
Rutherford Laboratory

Chilton, Didcot, Oxfordshire
OX11 0QX

Telephone Abingdon 21900
Telegrams Ruthlab Abingdon
Telex 83159